



US 20050200249A1

(19) **United States**

(12) **Patent Application Publication** (10) **Pub. No.: US 2005/0200249 A1**

Voon et al.

(43) **Pub. Date: Sep. 15, 2005**

(54) **STORAGE COMPARTMENT, AND RELATED COMPUTER SYSTEMS AND METHODS**

Publication Classification

(51) **Int. Cl.⁷ A47B 97/00**

(52) **U.S. Cl. 312/223.3**

(76) Inventors: **Sze-Moey Voon**, Cupertino, CA (US);
Thomas S. Neal, Cupertino, CA (US);
Ameer Karim, Cupertino, CA (US);
Joel Jacobs, San Francisco, CA (US)

(57) **ABSTRACT**

Correspondence Address:

HEWLETT PACKARD COMPANY
P O BOX 272400, 3404 E. HARMONY ROAD
INTELLECTUAL PROPERTY
ADMINISTRATION
FORT COLLINS, CO 80527-2400 (US)

A storage compartment to store one or more items includes a body, a top, and a coupling element operable to couple the top to the body and allow the top to be moved relative to the body. The body includes a bottom and a sidewall that define an interior in which one or more items, such as a storage medium or a portable device, may be stored. The sidewall includes a passage to allow an item stored in the interior to be coupled to another item outside the interior. The top may be moved relative to the body to open and close the storage compartment. With the storage compartment, one may securely and safely store a PDA, for example, that is coupled with a processor of a computer system.

(21) Appl. No.: **10/800,234**

(22) Filed: **Mar. 12, 2004**

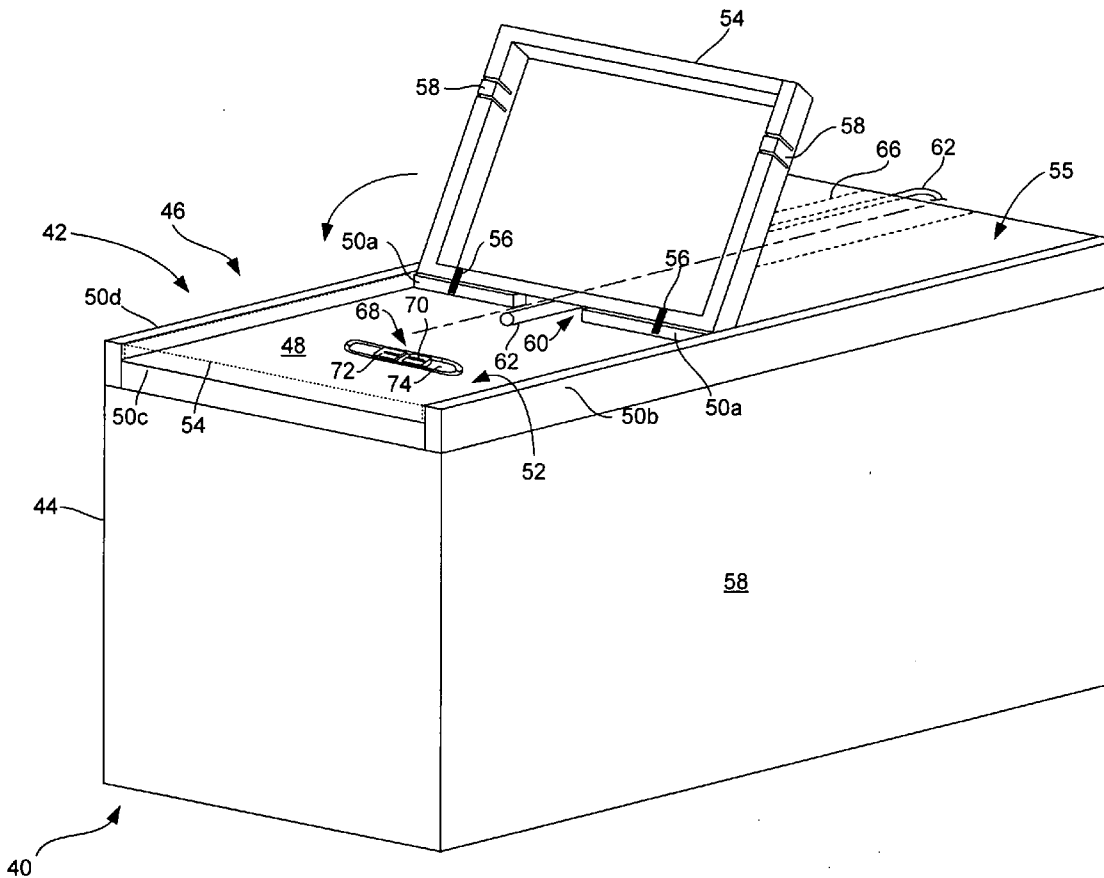

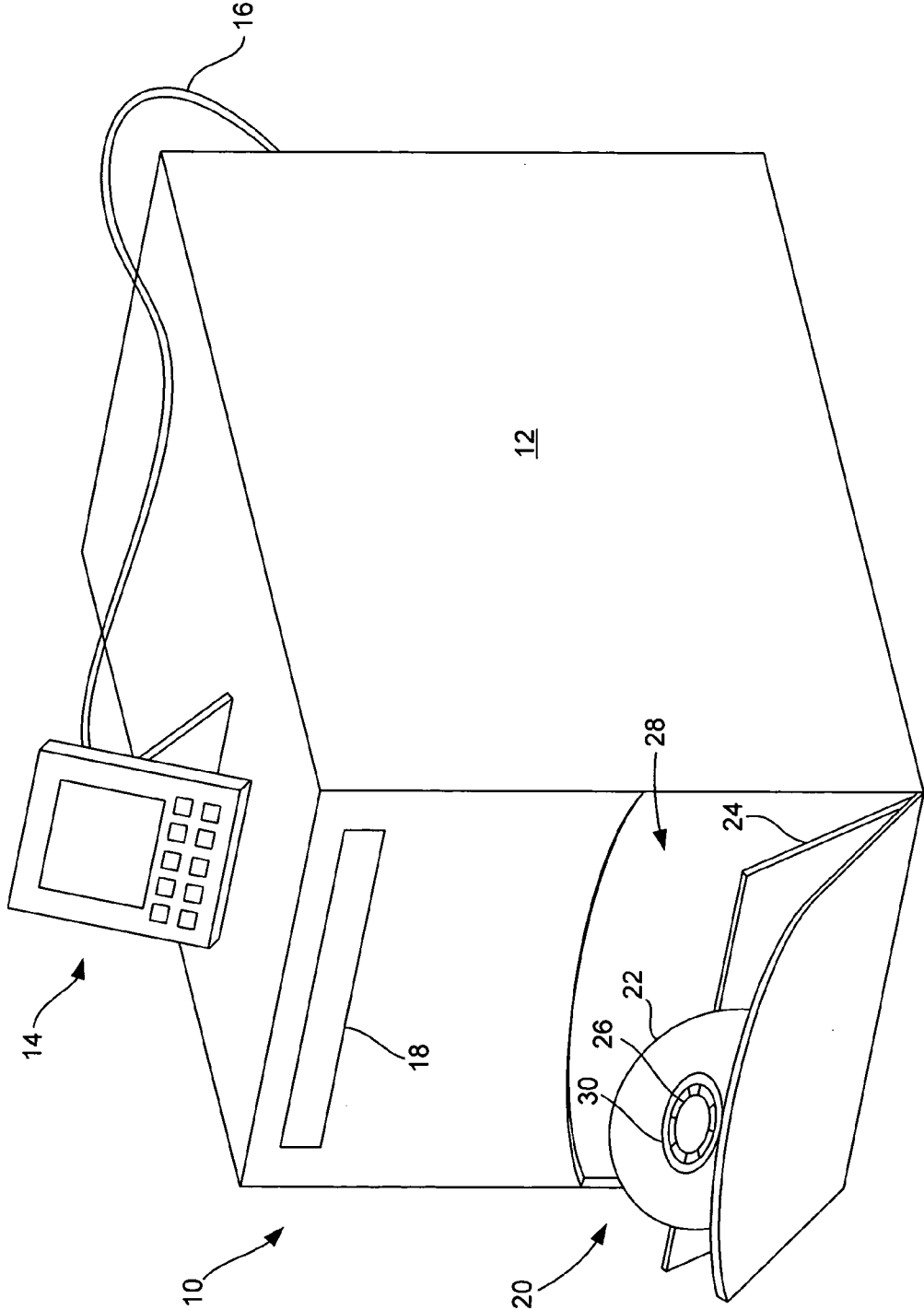
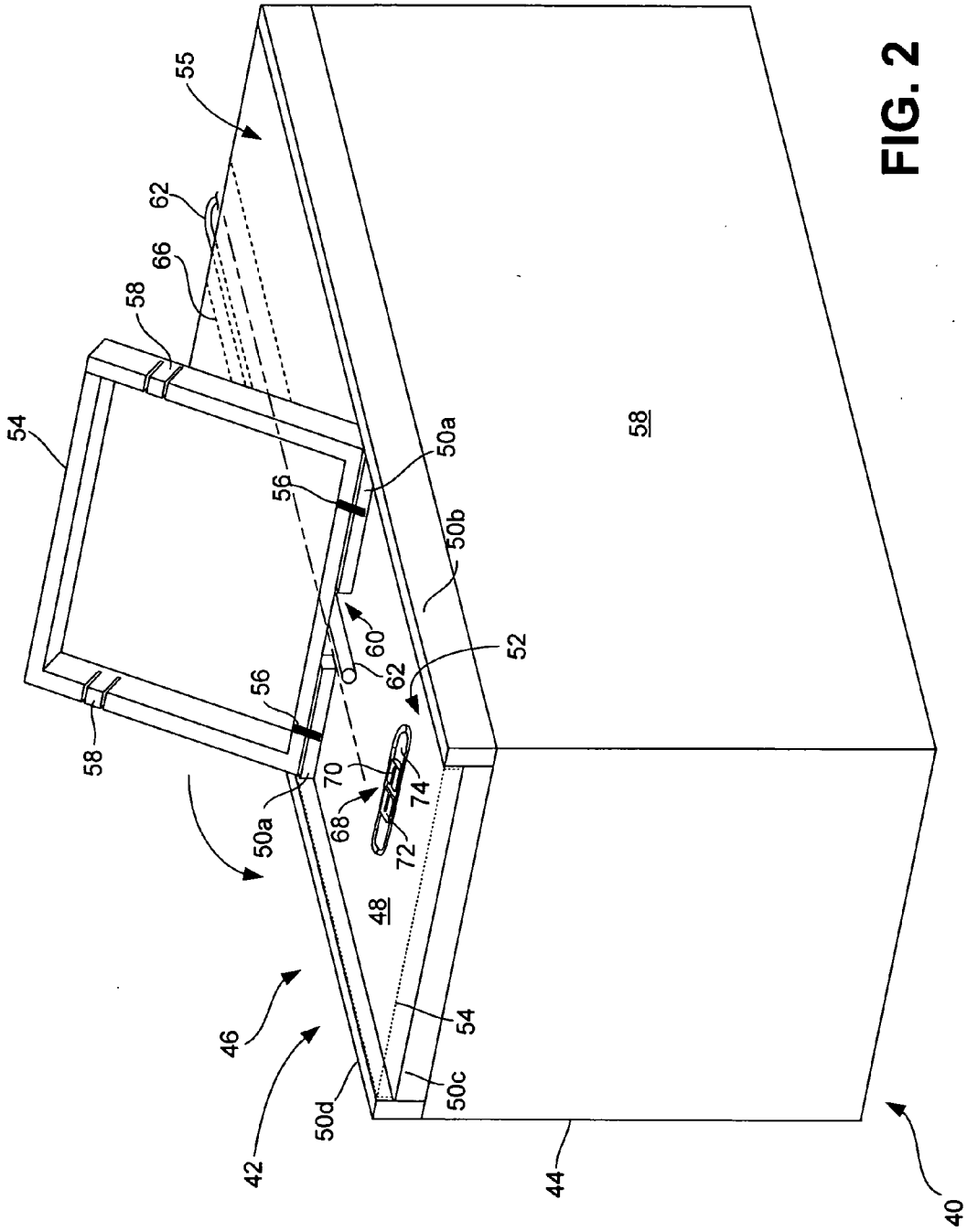

FIG. 1 (PRIOR ART)



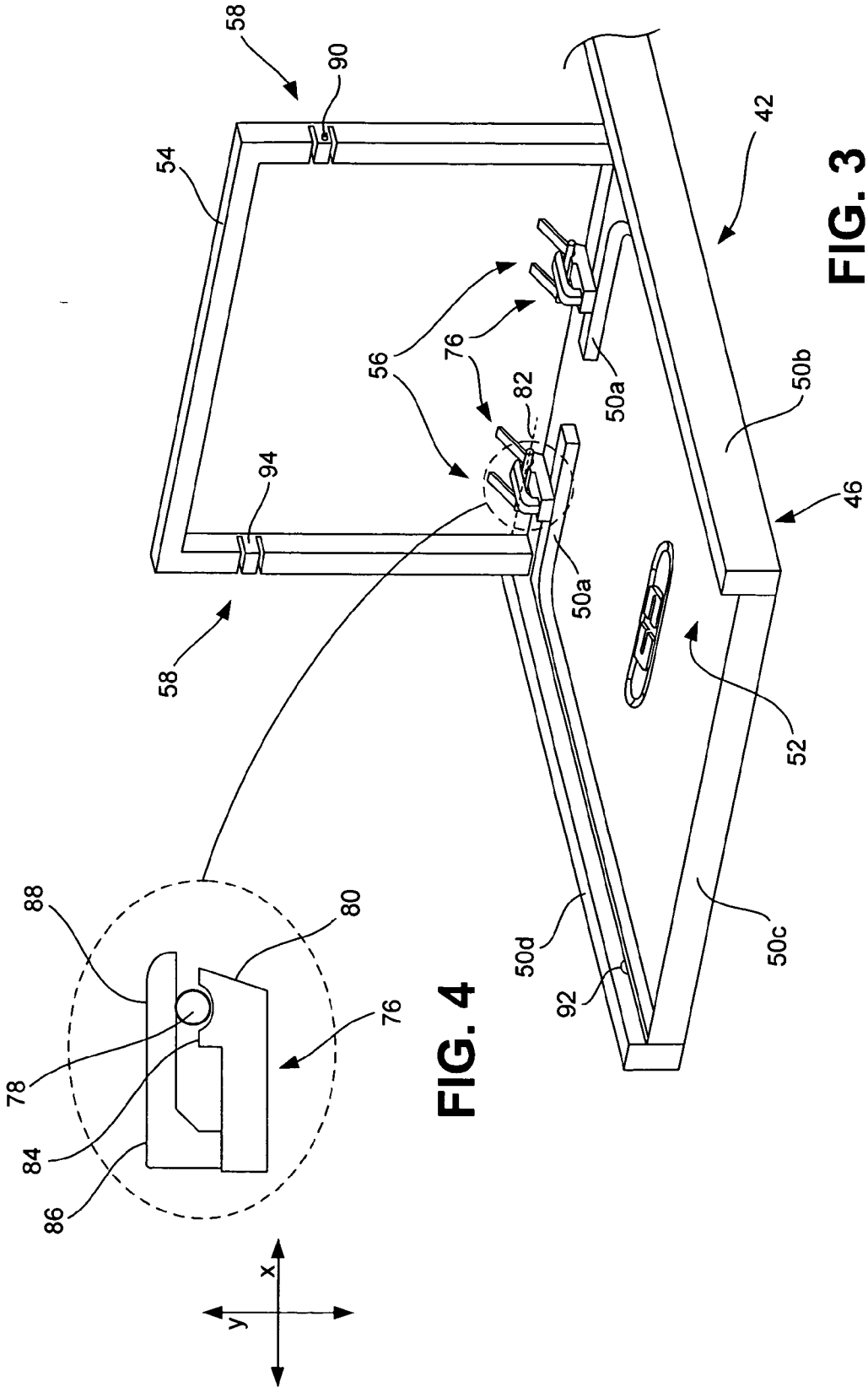

FIG. 3

FIG. 4

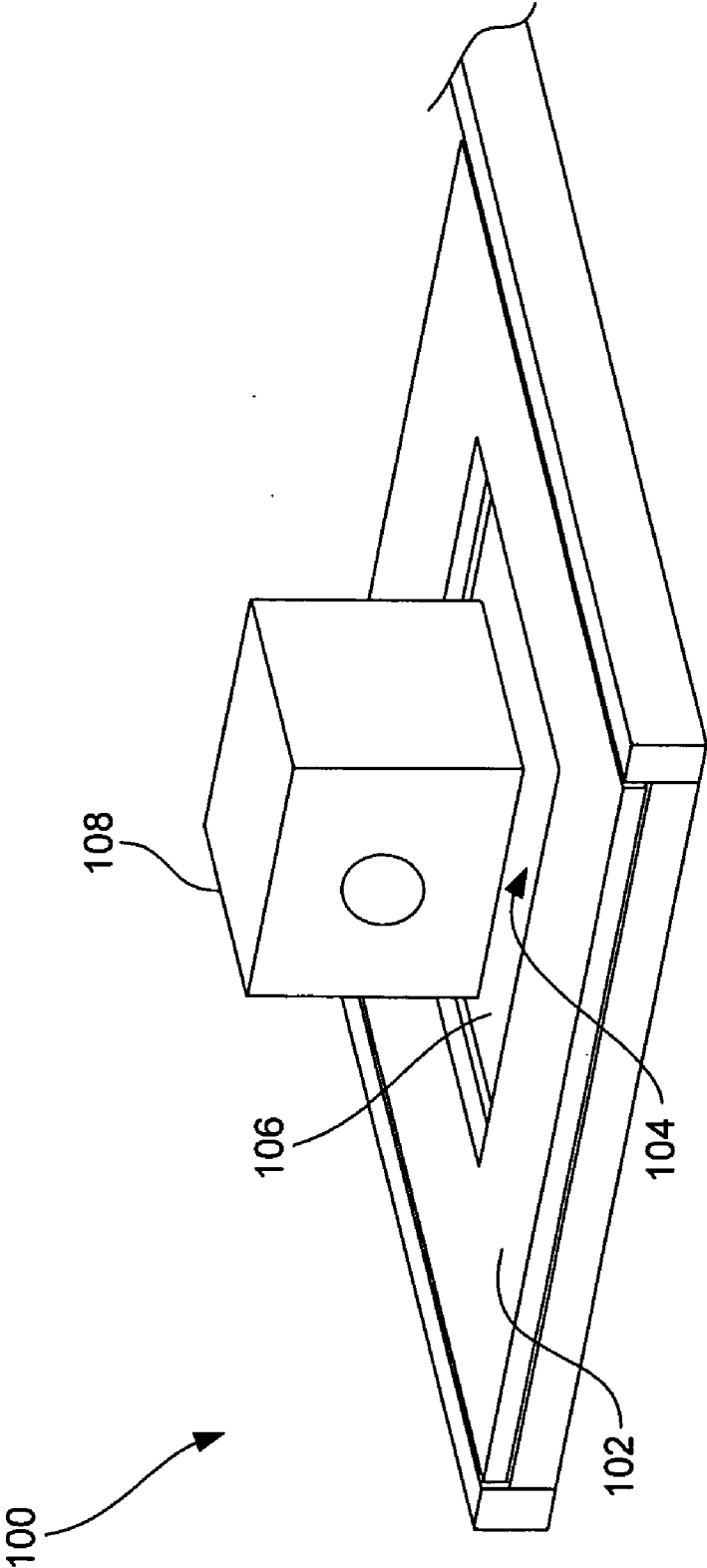

FIG. 5

STORAGE COMPARTMENT, AND RELATED COMPUTER SYSTEMS AND METHODS

CROSS-REFERENCED APPLICATIONS

[0001] This application is related to the following patent applications: U.S. Utility patent application Ser. No. _____ titled STORAGE COMPARTMENT WITH POSITIONABLE HOLDER FOR HOLDING A COMPACT DISC, attorney docket number 200314060-1 (1964-45-3), filed on 12 Mar. 2004; U.S. Utility patent application Ser. No. _____ titled HOUSING HAVING A CABLE CONDUIT AND RELATED SYSTEMS AND METHODS, attorney docket number 200314056-1 (1964-49-3), filed on 12 Mar. 2004; U.S. Design patent application Ser. No. _____ titled PORTION OF A HOUSING FOR PROCESSING CIRCUITRY OR OTHER SIMILAR ITEM, attorney docket number 200314058-1 (1964-47-5), filed on 12 Mar. 2004; and U.S. Design patent application Ser. No. _____ titled POWER SWITCH FOR PROCESSING CIRCUITRY OR OTHER SIMILAR ITEM, attorney docket number 200402715-1 (1964-47-6), filed on 12 Mar. 2004, which are incorporated by reference.

BACKGROUND

[0002] Many computer systems include processing circuitry for performing various computing functions, such as receiving and generating data and executing instructions, and include one or more portable devices, such as, for example, a personal data assistant (PDA) and/or a camera, that may be coupled to the circuitry. When a portable device is coupled to the processing circuitry, the circuitry can write data to or read data from the device, or otherwise control the operation of the device.

[0003] FIG. 1 is a perspective view of a computer system 10, which includes a housing 12 that protects processing circuitry (not shown) located inside the housing, a portable device 14 (here, a PDA), and a cable 16 that couples the PDA to the circuitry via an external connector (not shown). When the PDA 14 is coupled to the processing circuitry, it is typically set on top of the housing 12. The computer system 10 also includes a storage device 18 that reads data stored on a removable storage medium and that writes data to the medium, and a storage compartment 20 designed to store one or more removable storage media 22 when the media are not being used. For example, the storage device 18 may be a disc drive, such as a compact disc read-write (CDRW) drive and/or a digital versatile disc (DVD) drive, that transfers data to and from the removable storage media 22, such as, for example, a compact disc or a dvd, after the media has been inserted into the drive. The storage compartment 20 includes a support 24 with a shaft 26 to hold the compact disc 22 in an interior 28 of the compartment. To store the compact disc 22 in the compartment 20, one typically pushes a hole 30 of the disc onto the shaft 26.

[0004] Unfortunately, when the PDA 14 is placed on top of the housing 12, the PDA is exposed and susceptible to inadvertent contact with one's arm, hand or other object. Therefore, because the PDA 14 is not secured to the housing 12, one may inadvertently knock the PDA over and/or off the housing and, thus, may inadvertently damage the PDA.

[0005] One way to protect the PDA 14 is placing the PDA in the storage compartment 20, but this typically will not

adequately protect the PDA. Because the storage compartment 20 is designed to store one or more removable storage media 22, not a device that is typically heavier and bulkier, the storage compartment typically does not have enough space to store the PDA 14. For example, the support 24 in the storage compartment 20 may occupy much of the space that the PDA 14 would otherwise occupy if stored in the compartment. Thus, when the PDA 14 is placed in the storage compartment 20, a portion of the PDA typically remains exposed and susceptible to inadvertent contact.

SUMMARY

[0006] In one aspect of the invention, a storage compartment of a housing includes a body having an interior and a passage operable to allow an item disposed within the interior to be communicatively coupled to another item outside the interior, and a lid. The body includes a bottom and a sidewall that define the interior in which one or more items, such as a storage medium or a portable device, may be stored. The lid may be moved relative to the body to open and close the storage compartment. When opened, one may insert or remove an item from the storage compartment, and when closed, an item located in the storage compartment may be protected against inadvertent contact. With the storage compartment, one may securely and safely store a PDA, for example, that is coupled to processing circuitry of a computer system.

[0007] In another aspect of the invention, a storage compartment of a housing includes a body having an interior, a bottom and a sidewall that define the interior, and a lid having an opening operable to allow access to an item disposed within the interior. With the opening in the lid, one may store an item that is larger than the interior by allowing the item to protrude through the opening. In addition, one may store a coupler in the interior and couple a device to the coupler through the opening.

BRIEF DESCRIPTION OF THE FIGURES

[0008] FIG. 1 is a perspective view of a conventional computer system that includes a PDA placed on top of the system's housing.

[0009] FIG. 2 is a perspective view of a computer system that incorporates a storage compartment according to an embodiment of the invention.

[0010] FIG. 3 is a perspective view of the storage compartment in FIG. 2 with a top in an open position according to an embodiment of the invention.

[0011] FIG. 4 is a side view of a coupling element in FIG. 3 that couples the top to the body of the storage compartment in FIGS. 2 and 3, according to an embodiment of the invention.

[0012] FIG. 5 is a perspective view of a storage compartment according to another embodiment of the invention.

DETAILED DESCRIPTION

[0013] FIG. 2 is a perspective view of a computer system 40 that includes a storage compartment 42 according to an embodiment of the invention. The storage compartment 42 may be incorporated into a housing 44 of the computer system 40 as shown, or the storage compartment may be

separate from the system. The storage compartment 42 includes a body 46 having a bottom 48 and a side 50 that define an interior 52 in which one or more items (not shown) may be securely stored. For example, one or more portable electronic devices, such as a PDA, personal information manager (PIM), a camera, and/or camera docking station, may be stored in the interior, as well as removable storage media. The storage compartment 42 also includes a lid 54 and a coupling element 56 (discussed in greater detail in conjunction with FIG. 3) to couple the top to the body 46 and allow one to open and close the compartment by moving the top relative to the body. When the storage compartment 42 is closed as illustrated here by the lid 54 shown in dashed lines, an item stored in the interior 52 is protected against being inadvertently knocked over and/or off the housing 44. Thus, with the storage compartment 42, one may securely store a PDA, for example, that is coupled to (or uncoupled from) processing circuitry (not shown) of the system 40.

[0014] Although the storage compartment 42 is shown located along the top 55 of the housing 44, the storage compartment may be located along the sides of the housing, or along the front of the housing 44 similar to the storage compartment 20 of the computer system 10 in FIG. 1. When located along the sides or front of the housing 44, the storage compartment 42 may include an item retention component, such as, for example, a strap (not shown) to help retain an item in the compartment. In addition, although the computer system 40 is shown in FIG. 2 with the housing 44 in a tower configuration, the housing may be in a desktop configuration.

[0015] Still referring to FIG. 2, the storage compartment 42 may also include a locking element 58 (discussed in greater detail in conjunction with FIG. 3) to retain the lid 54 in a position relative to the body 46. For example, in one embodiment, the locking element 58 may retain the lid 54 in the closed position (dashed line), that is, the position where the lid is parallel to the top 55 and, thus, prevents access to the storage compartment. Thus, in the closed position, the lid 54 forms a barrier between the interior 52 and the outside environment above the interior 52 to prevent objects, such as, for example one's arm, from contacting an item stored in the interior. In the open position (solid line), the lid 54 allows one to remove an item stored in the interior 52, or insert an item into the interior. By retaining the lid 54 in the closed position, the locking element 58 reduces the chance that the lid may be inadvertently moved to an open position. Thus, the storage compartment 42 can more securely store and better protect an item stored in the interior 52.

[0016] Still referring to FIG. 2, one or more of the sides 50a-50d may include an passage 60 to allow a cable 62 to couple an electronic device (not shown in FIG. 2) to a processing circuitry (not shown) of the computer system 40. With the passage 60, one may store a portable electronic device such as, for example, a PDA, in the storage compartment 42 to protect the PDA while the processor reads or writes data to the PDA. In one embodiment, the passage 60 may be located in the back side 50a. The passage 60 may also be aligned with an opening (not shown) of a conduit 66 that reduces the exposure of the cable 62 as it extends from the PDA to a connector, which is typically located on the back (not shown) of the housing 44. The conduit 66 is further discussed in U.S. patent application Ser. No. _____ titled HOUSING HAVING A CABLE CONDUIT AND

RELATED SYSTEMS AND METHODS, and filed _____, which is incorporated by reference. In operation, one may insert the PDA into the storage compartment 42, couple the cable 62 to the PDA, and close the lid 54 to protect the PDA.

[0017] Still referring to FIG. 2, the storage compartment 42 may also include a positionable post 68 that may be positioned relative to the body 46 to retain one or more storage media (not shown in FIG. 2) such as compact discs, in the compartment, and that may be re-positioned to store other items, such as a PDA, in the compartment. For example, in one embodiment, the post may include a first component 70 and a second component 72 that may be positioned independently of each other. When each component 70 and 72 is positioned in a respective first position, each component lies in a receptacle 74 substantially parallel to the bottom 48 of the compartment 42. In the receptacle 74 the components 70 and 72 do not extend into the interior 52, thus allowing one to store items, such as a PDA, other than a compact disc. When each component 70 and 72 is positioned in a respective second position (not shown), each component extends into the interior 52 substantially perpendicular to the bottom 48. In the second position the components 70 and 72 form a post that may retain one or more storage media by engaging a center hole of the media. The positionable post 68 is further discussed in U.S. patent application Ser. No. _____ titled STORAGE COMPARTMENT WITH POSITIONABLE POST FOR HOLDING A COMPACT DISC AND RELATED SYSTEMS AND METHODS, and filed _____, which was previously incorporated by reference.

[0018] FIG. 3 is a perspective view of the storage compartment 42 in FIG. 2 with the lid 54 in an open position according to an embodiment of the invention. FIG. 4 is a side view of the coupling element 56 in FIGS. 2 and 3, according to an embodiment of the invention.

[0019] Referring to FIGS. 3 and 4, the coupling element 56 couples the lid 54 to the body 46 and allows one to move the lid 54 relative to the body 46 to open and close the compartment 42. In one embodiment, the coupling element 56 may be a hinge 76 that releasably couples the lid 54 to the back side 50a. The hinge 76 may include a shaft 78, and a receiver 80 that retains the shaft and allows the shaft to rotate about the shaft's axis 82. Thus, one pivots the lid 54 relative to the back 50a to open and close the storage compartment 42. To retain the shaft 78, the receiver 80 includes a receptacle 84 to restrain movement of the shaft in the X direction, and a cantilevered member 86 to restrain movement of the shaft in the Y direction. The cantilevered member 86 includes an end 88 located above the receptacle 84 a distance that is less than the diameter of the shaft, and thus, the member urges the shaft to remain in the receptacle. To separate the shaft 78 from the receiver 80, and thus release the lid 54 from the back 50a, one moves the end 88 away from the receptacle 84 and removes the shaft from the receptacle. To engage the shaft 78 with the receiver 80, one moves the end 88 away from the receptacle 84 and inserts the shaft into the receptacle.

[0020] Other embodiments are contemplated. For example, the hinge 76 may couple the lid 54 to other areas of the body 46, such as the sides 50a-50b (FIG. 2) and/or the bottom 48. In another example, the hinge 76 may permanently couple the lid 54 to the body 46. In yet another

example, the coupling element **56** may include a track that the lid **54** slides on to open and close the storage compartment **42**.

[0021] Still referring to **FIG. 3**, the locking element **58** retains the lid **54** in a position relative to the body **46**. For example, in one embodiment, the locking element **58** retains the lid **54** in a closed position, and includes two locking-element protrusions **90** (only one shown for clarity) and two locking-element receptacles **92** (only one shown for clarity). When the lid **54** is closed, each locking element protrusion **90** is aligned with a respective one of the locking-element receptacles **92**, and urged toward their respective receptacles **92** by a cantilevered post **94** to engage the receptacles. With both locking-element protrusions **90** inserted into a locking-element receptacle **92**, the locking element **58** retains the body **38** in the closed position. To unlock the lid **54**, one pulls and/or pushes the top with sufficient force to cause the locking-element receptacles **92** to urge the respective locking-element protrusions **90** toward each other, and thus out of the receptacles.

[0022] Other embodiments are contemplated. For example, the locking element **58** may include one or more than two locking-element protrusions and corresponding locking-element receptacles. In another example, the locking element **58** may include a screw, snap and/or strap to retain the lid **54** at the closed position. In yet another example, the locking element **58** may retain the lid **54** in a position relative to the body **46** where the lid **54** does not close the storage compartment **42**.

[0023] Still referring to **FIG. 3**, the storage compartment **42** may be made of any desirable material, and sized and formed as desired. For example, in one embodiment the storage compartment **42** is formed by casting conventional plastic in a mold, is square shaped and approximately one inch deep. The lid **54** includes an outer surface (not shown) that is substantially flat and extends over substantially all of the interior **52** when closed. The lid **54** may also support an item when the lid **54** is closed, and thus, one may place one or more items on the lid **54** and store one or more items in the storage compartment **42** at the same time.

[0024] Other embodiments are contemplated. For example, the storage compartment **42** may have other shapes, such as circular, rectangular or polygonal, and may be more or less than one inch deep. In another example, the lid **54** may extend over only a portion of the interior **52**. In yet another example, the lid may include a receptacle in the outer surface sized to receive and retain an item, or the outer surface may be concave or convex.

[0025] **FIG. 5** is a perspective view of a storage compartment **100** that includes a lid **102** having an opening **104** according to another embodiment of the invention. The lid **102** may include a cover (not shown) to open and close the opening; or the lid may not include a cover. The opening **104** may be any shape and size desired to allow one to access an item stored in the storage compartment **100**. This may be desirable to store an item that is larger than the interior (not shown) of the storage compartment **100**, such that the item can protrude through the opening **104**. This may also be desirable to store a coupler in the storage compartment **100** and couple a device to the coupler through the opening **104**.

[0026] For example, one may store a camera docking station **106** that may be used to couple a camera **108** to the

processing circuitry and/or a power source (not shown). When stored in the storage compartment **100**, the camera docking station **106** may be coupled to the circuitry via a cable (not shown) as previously discussed in conjunction with **FIG. 2**. When the circuitry is coupled to the camera **108**, the circuitry may write and/or read data from the camera to generate a picture, and the power source may recharge the camera's batteries. To couple the camera **108** to the circuitry and/or power source, a plug (not shown) of the docking station **106** is typically inserted into a receptacle (not shown) of the camera **108**. Thus, when the camera is frequently used, one can easily engage and disengage the camera's receptacle from the docking station's plug.

[0027] Without the opening **104**, one would have to move the lid **102** to an open position to engage the camera's receptacle with the docking station's plug. If the camera is then knocked over, the docking station could easily follow, and thus both the camera and the docking station could be damaged. With the opening **104**, however, one can couple the camera **108** to the docking station **106** while the docking station is safely stored in the storage compartment **100** and the lid **102** is locked in the closed position.

[0028] The preceding discussion is presented to enable one skilled in the art to make and use the invention. Various modifications to the disclosed embodiments will be readily apparent to those skilled in the art, and the generic principles herein may be applied to other embodiments and applications without departing from the spirit and scope of the present invention. Thus, the present invention is not intended to be limited to the embodiments shown, but is to be accorded the widest scope consistent with the principles and features disclosed herein.

What is claimed is:

1. A housing for a computer system, the housing comprising:

a storage compartment including:

a body having an interior, a bottom and a sidewall that define the interior, and a passage operable to allow an item disposed within the interior to be communicatively coupled to another item outside the interior; and

a lid.

2. The housing of claim 1 wherein the interior is sized to retain a PDA.

3. The housing of claim 1 wherein the interior is sized to hold storage media.

4. The housing of claim 1 wherein the sidewall includes the passage.

5. The housing of claim 1 wherein the storage compartment includes a coupling element operable to couple the lid to the sidewall.

6. The housing of claim 1 wherein the storage compartment includes a locking element operable to retain the lid in a closed position.

7. The housing of claim 1 wherein:

the housing further comprises a conduit having an opening; and

the passage opens to the conduit's opening.

8. A housing for a computer system, the housing comprising:

a storage compartment including:

a body having an interior, a bottom and a sidewall that define the interior, and

a lid having an opening operable to allow access to an item disposed within the interior.

9. The housing of claim 8 wherein the interior is sized to retain a camera docking station, and when a camera is coupled to the docking station, the camera protrudes through the opening.

10. A computer system comprising:

a housing having a storage compartment to retain an item and including:

a body having an interior, a bottom and a sidewall that define the interior, and a passage operable to allow an item disposed within the interior to be communicatively coupled to another item outside the interior; and

a lid.

11. A computer system comprising:

a housing having a storage compartment to retain an item and including:

a body having an interior, a bottom and a sidewall that define the interior, and

a lid having an opening operable to allow an item disposed within the interior to protrude through the opening.

12. A method for storing an item, the method comprising:

placing an item in an interior of a storage compartment that includes a lid and a body having a bottom and a sidewall that define the interior;

extending a cable from the exterior of the storage compartment through a passage in the body; and

coupling the cable to the item in the interior.

13. The method of claim 12 wherein extending a cable from the exterior of the storage compartment includes extending the cable through an opening of a conduit.

14. The method of claim 12 further comprising closing the lid.

15. The method of claim 12 further comprising:

closing the lid, and

supporting another item on the lid.

16. A method for storing an item, the method comprising:

placing an item in an interior of a storage compartment that includes a lid having an opening, and a body having a bottom and a sidewall that define the interior;

inserting another item through the opening; and

coupling the items together.

* * * * *